

NL

EN

FR

DE

ES

HR

qSense



**Gebruikers-
handleiding
User Guide
Notice
d'utilisation
Bedienungs-
Anleitung
Vodić za
korisnike**

Contents

1.1	Inleiding / Introduction / Introduction / Einleitung / Introducción / Uvod	2
1.2	Installatie / Installation / Installation / Installieren / Implantación / Installacija	3
1.3	Bedieningspaneel / Control panel / Tableau de commande / Schaltfeld / Cuadro de mando / Kontrolna ploča	4
1.4	Instellingen wijzigen / Changing the settings / Modification des réglages / Änderung der Einstellungen / Modificación de los ajustes / Promjena postavki	6
1.5	Meldingen / Messages / Messages / Meldungen / Mensajes / Poruke	8
1.6	Technische gegevens / Technical data / Caractéristiques techniques / Technische Daten / Características técnicas / Tehnički podatci.....	9

1.1 Inleiding / Introduction / //Introduction / Einleitung / Introducción / Uvod

<p>(NL)</p>	<p>De Remeha qSense is een modulerende OpenTherm thermostaat. Door middel van een draai/drukknop kan snel en eenvoudig de kamertemperatuur gewijzigd worden. Tevens kunnen er (afhankelijk van de ketel) parameters gewijzigd worden. Deze gebruikershandleiding behandelt alleen de thermostaatfunctie van de qSense. Een volledige beschrijving van de extra functies vindt u in de installatie- en servicehandleiding. Deze kunt u downloaden via nl.remeha.com.</p>
<p>(EN)</p>	<p>The Remeha qSense is a modulating OpenTherm thermostat. By means of a rotary and push button it's possible to change the room temperature quickly and easily. It's also possible (depending on the boiler) to change parameters. This user guide only covers the thermostat function of the qSense. A complete description of the additional functions can be found in the installation and service manual. This can be downloaded from nl.remeha.com.</p>
<p>(FR)</p>	<p>Le Remeha qSense est un thermostat modulant de OpenTherm. Le bouton rotatif à pression permet un réglage simple et rapide de la température de la pièce. Il est également possible de modifier les paramètres (en fonction de la chaudière). Ce guide d'utilisation couvre uniquement la fonction thermostat de qSense. Une description complète des fonctions complémentaires est disponible dans le manuel d'installation et d'entretien. Cette documentation peut être téléchargée sur nl.remeha.com.</p>
<p>(DE)</p>	<p>Die Remeha qSense ist ein modulierendes OpenTherm Thermostat. Durch die Betätigung des Drehtasters kann die Raumtemperatur schnell und einfach verändert werden. Abhängig vom Kessel ist es auch möglich, die Parameter zu ändern. Diese Bedienungsanleitung behandelt nur die Thermostatfunktion von qSense. Eine vollständige Beschreibung der zusätzlichen Anweisungen finden Sie in der Installations- und Wartungsanleitung. Die Sie unter nl.remeha.com herunterladen können.</p>
<p>(ES)</p>	<p>El Remeha qSense es un termostato OpenTherm de modulación. Por medio de un botón giratorio y pulsador se puede cambiar la temperatura ambiente rápida y fácilmente. También se pueden cambiar los parámetros (según la caldera). Esta guía del usuario solo cubre la función del termostato del qSense. Puede encontrar una descripción completa de las funciones adicionales en el manual de instalación y servicio. Esto se puede descargar de nl.remeha.com.</p>
<p>HR</p>	<p>Remeha qSense je modulirajući OpenTherm termostat. Pomoću rotacijske/pritisne tipke moguće je brzo i jednostavno promijeniti temperaturu prostorije. Također je moguće (ovisno obojleru) za promjenu parametara. Ovaj korisnički vodič pokriva samo funkcije qSensetermostata. Potpun opis dodatnih funkcija može se naći u ugradnja i servis priručniku. To se može skinuti s nl.remeha.com.</p>

1.2 Installatie / Installation / Installation / Installieren / Implantación / Instalacija

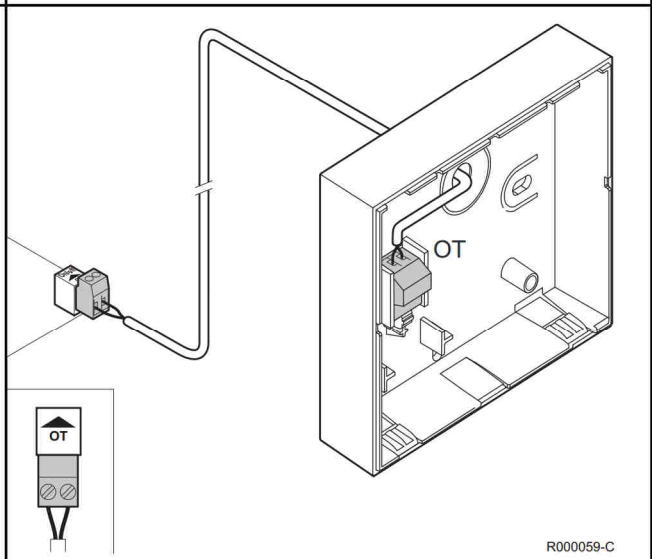
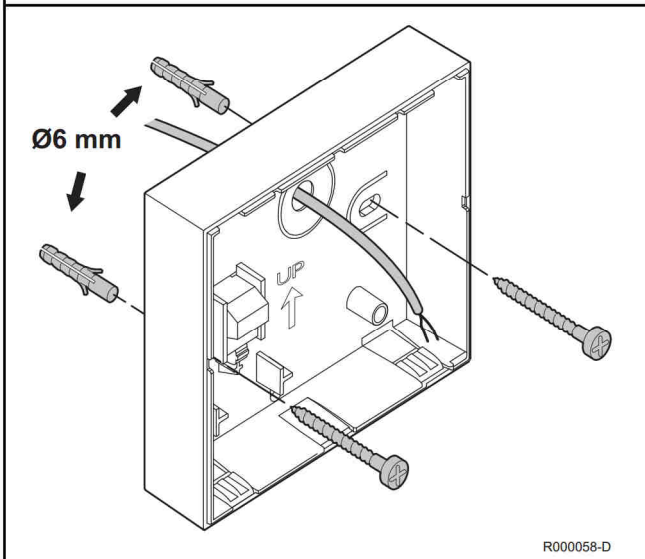
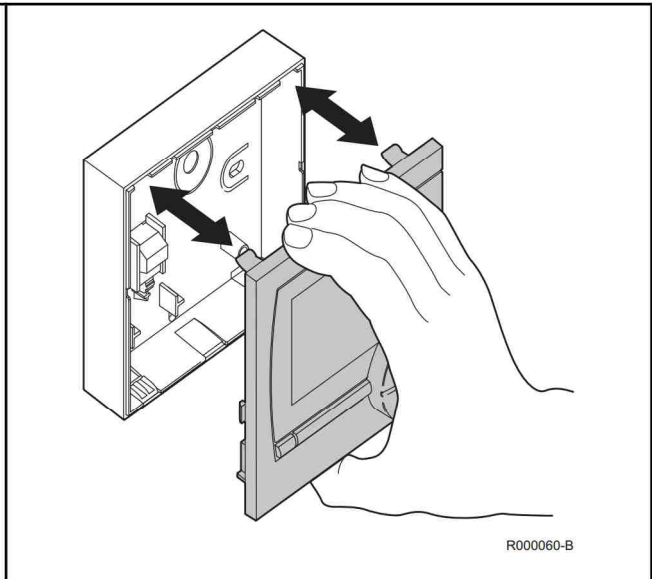
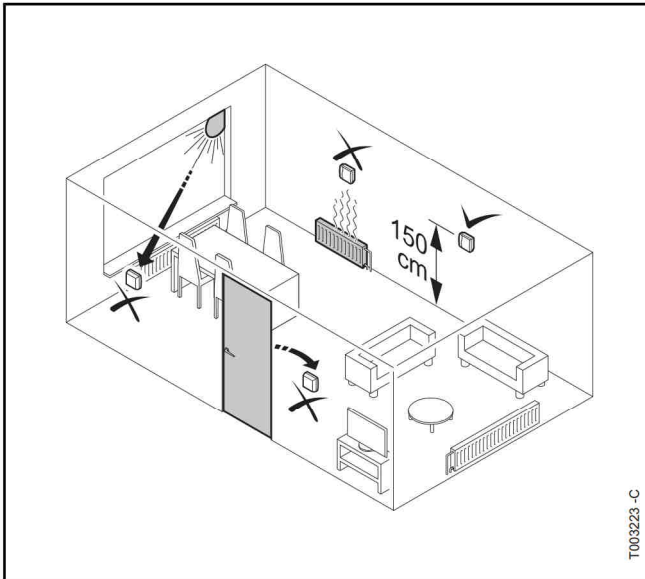

1.3 Bedieningspaneel / Control panel / Tableau de commande / Schaltfeld / Cuadro de mando / Kontrolna ploča

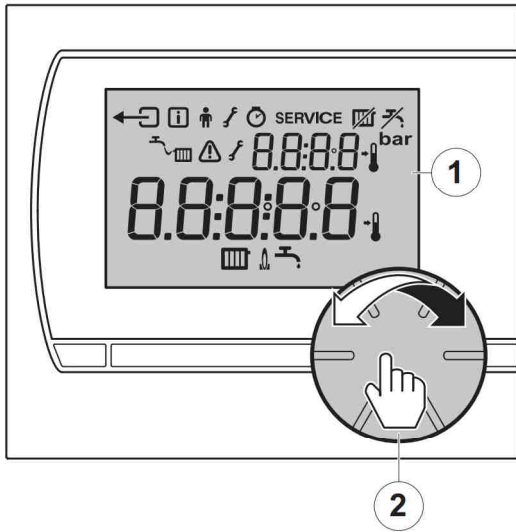

- 1 Display
Display
Afficheur
Display
Pantalla
Ekran
- 2 Draai- en drukknop
Rotary and push button
Bouton rotatif et poussoir
Druck- und Dreh-Knopf Botón rotativo y pulsador
Rotirajuće/pritisna tipka



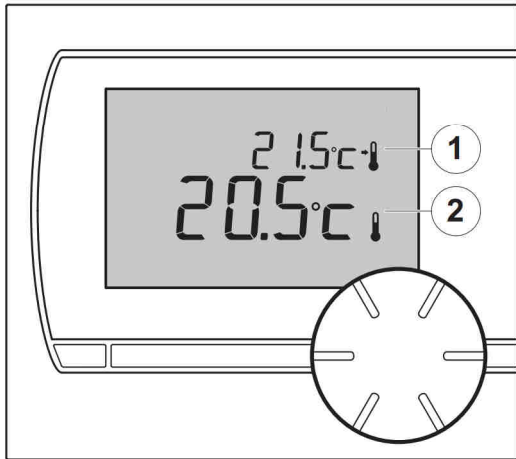

R000057-D







- 1 Ingestelde temperatuur
Set temperature
Température réglée
Eingestellte Temperatur
Temperatura de ajuste
Zadana temperatura
- 2 Gemeten temperatuur
Measured temperature
Température mesurée
Gemessene Temperatur
Temperatura medida
Mjerena temperatura

R000077-A

Symbolen / Symbols / Symboles / Symbole / Símbolos / Simboli					
✖	(NL)	ECO stand aan	→	(NL)	Ingestelde temperatuur
	(EN)	ECO mode on		(EN)	Set temperature
	(FR)	Mode ECO activé		(FR)	Température réglée
	(DE)	ECO Modus aktiviert		(DE)	Eingestellte Temperatur
	(ES)	Modo ECO activado		(ES)	Temperatura de ajuste
	HR)	Eco mod uključen		HR)	Zadana temperatura
🚰	(NL)	Waterdruk te laag	🏠	(NL)	Centrale verwarming functie aan
	(EN)	Water pressure too low		(EN)	Central heating mode on
	(FR)	Pression d'eau trop faible		(FR)	Le Mode chauffage central activé
	(DE)	Wasserdruck zu gering		(DE)	Heizung Betrieb aktiviert
	(ES)	Presión del agua demasiado baja		(ES)	El mode calefacción activado
	HR)	Pritisak vode pre nizak		HR)	Mod grijanja uključen

Symbolen / Symbols / Symboles / Symbole / Símbolos / Simboli					
	(NL)	Storing		(NL)	Brander aan
	(EN)	Fault		(EN)	Burner on
	(FR)	Dérangement		(FR)	Brûleur activé
	(DE)	Störung		(DE)	Brenner aktiviert
	(ES)	Avería		(ES)	Quemador activado
	(HR)	Greška		(HR)	Uključen plamenik
	(NL)	Service nodig aan de ketel		(NL)	Sanitair warm water functie aan
	(EN)	Boiler service required		(EN)	Domestic hot water mode on
	(FR)	La chaudière nécessite une intervention		(FR)	Le mode eau chaude sanitaire activé
	(DE)	Der Heizkessel muss gewartet werden		(DE)	Warmwasser Betrieb aktiviert
	(ES)	La caldera precisa mantenimiento		(ES)	El mode agua caliente sanitaria activado
	(HR)	Potrebna SERVIS		(HR)	Mod sanitarne vode uključen
	(NL)	Gemeten temperatuur			
	(EN)	Measured temperature			
	(FR)	Température mesurée			
	(DE)	Gemessene Temperatur			
	(ES)	Temperatura medida			
	(HR)	Temperatura izmjerena			

Menusymbolen / Menu symbols / Symboles menu / Menü Symbole / Símbolos menú / Simboli meni					
	(NL)	Terug		(NL)	Service menu
	(EN)	Back		(EN)	Service menu
	(FR)	Retour		(FR)	Menu entretien
	(DE)	Zurück		(DE)	Wartungsmenü
	(ES)	Volver		(ES)	Menú mantenimiento
	(HR)	Izlaz		(HR)	Servisni meni
	(NL)	Informatiemenu		(NL)	Urentellermenu
	(EN)	Information menu		(EN)	Hour counter menu
	(FR)	Menu information		(FR)	Menu compteur horaire
	(DE)	Informationmenü		(DE)	Betriebsstundenzähler-Menü
	(ES)	Menú información		(ES)	Menú contador horario
	(HR)	Informacijski meni		(HR)	meni podešavanja sata
	(NL)	Gebruikersmenu	SERVICE	(NL)	Service melding
	(EN)	User menu		(EN)	Maintenance message
	(FR)	Menu Utilisateur		(FR)	Message d'entretien
	(DE)	Benutzermenü		(DE)	Wartungsmeldung
	(ES)	Menú usuario		(ES)	Mensaje de mantenimiento
	(HR)	Korisnički meni		(HR)	Poruka za potrebom servisa

1.4 Instellingen wijzigen / Changing the settings / Modification des réglages / Änderung der Einstellungen / Modificación de los ajustes / Promjena postavki

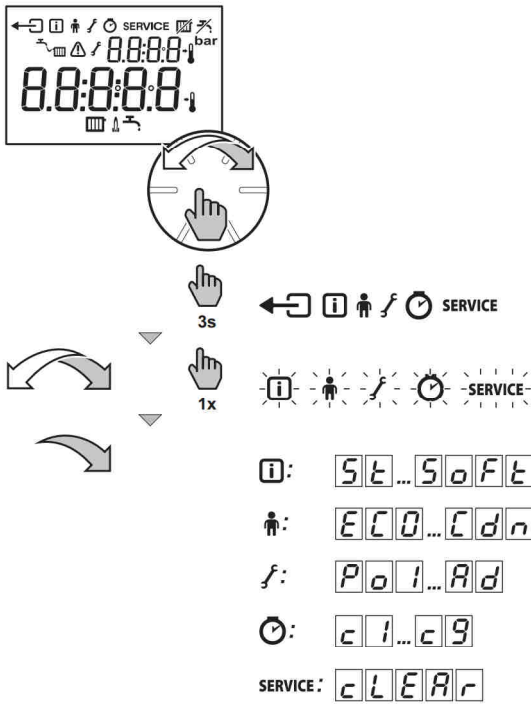



Menustructuur / Menu structure / Structure des menus / Menüstruktur / Estructura de menús / Sadržaj meni	
(NL)	Ga voor toegang tot het menu als volgt te werk.
(EN)	To gain acces to the menu, proceed as follows.
(FR)	Procédez comme suit pour accéder au menu.
(DE)	Um auf dieses Menü zuzugreifen, gehen Sie wie folgt vor.
(ES)	Para obtener acceso al menú, proceda de la siguiente forma.
HR	Kako bi ušli u postavke pratite sljedeće upute.

i / f / c / SERVICE	
(NL)	Zie de installatiehandleiding voor meer informatie.
(EN)	Refer to the installation instructions for further information.
(FR)	Se reporter à la notice d'installation pour des informations complémentaires.
(DE)	Siehe Installations-Anleitung für ergänzende Informationen.
(ES)	Referirse a las instrucciones de utilización si necesita información adicional.
HR	Pogledajte upute za ugradnju za više informacija











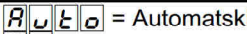
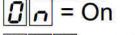

Code	Betekenis	Instellingen	Fabrieksinstelling
E c o	Tapwater-warmhoudfunctie	A u t o = Automatische stand O n = Aan O f f = Uit	Auto
E d H	Tapwater temperatuur	20 tot 75 °C	60 °C
E c H	Maximale CV-water temperatuur	0 tot 100 °C	90 °C
H u P	Opwarmsnelheid (CV)	2 = Snelst - 3 = Extra langzaam	0
C d n	Afkoelsnelheid (Woning)	2 = Snelst (Slecht geïsoleerd) - 2 = Langzaamst (Goed geïsoleerd)	0

 (EN)			
Code	Meaning	Settings	Factory setting
E C O	DHW standby function	R U E O = Automatic position O n = Start O F F = Stop	Auto
E d H	Tap water temperature	20 to 75 °C	60 °C
E c H	Maximum central heating water temperature	0 to 100 °C	90 °C
H u P	Heating rate (Central heating)	2 = Fastest - 3 = Extra Slow	0
C d n	Cooling rate (Residence)	2 = Fastest (Poorly insulated) - 2 = Slowest (Well insulated)	0











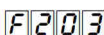

 (FR)			
Code	Signification	Paramètres	Réglage d'usine
E C O	Fonction de veille ECS	R U E O = Position automatique O n = Marche O F F = Arrêt	Auto
E d H	Température de l'eau du robinet	20 au 75°C	60 °C
E c H	Température maximum de l'eau pour le chauffage central	0 au 100°C	90 °C
H u P	Vitesse de chauffage (Chauffage central)	2 = Maxi - 3 = Très lent	0
C d n	Vitesse refroidissement (Résidence)	2 = Maxi (Isolation faible) - 2 = Mini (Bonne isolation)	0

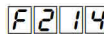

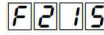



 (DE)			
Code	Bedeutung	Einstellungen	Werkseinstellung
E C O	Warmwasseroptimierung	R U E O = Automatik-Position O n = Ein O F F = Aus	Auto
E d H	WW-Temperatur	20 bis 75°C	60 °C
E c H	Maximale Wassertemperatur in der Heizung	0 bis 100°C	90 °C
H u P	Aufheizgeschwindigkeit (ZH)	2 = Schnellste - 3 = Extra langsame	0
C d n	Abkühlgeschwindigkeit (Wohnung)	2 = Schnellste (Schlecht isoliert) - 2 = Langsamer (Gut isoliert)	0

 (ES)			
Código	Significado	Ajustes	Ajuste de fábrica
E C O	Función de espera de agua caliente	R U E O = Posición automática O n = Marcha O F F = Parada	Auto
E d H	Temperatura PTV	20 do 75°C	60 °C
E c H	maksimalna temperatura centralnog grijanja	0 do 100°C	90 °C
H u P	Velocidad de (calentamiento)	2 = Muy rápida - 3 = Extra lenta	0
C d n	Velocidad de enfriamiento (Residencia)	2 = Muy rápida (Poco aislado) - 2 = Muy lenta (Bien aislado)	0

	HR		
Codice	Značenje	Postavke	Tvorničke postavke
	Funkcija PTV čekanje	 = Automatski  = On  = Off	Auto
	Temperatura dell'acqua corrente	20 a 75°C	60 °C
	Temperatura massima dell'acqua del riscaldamento centralizzato	0 a 100°C	90 °C
	Brzina zagrijavanja(centralno grijanje)	 = Vrlo brzo  = vrlo sporo	0
	Brzina hlađenja (Građevina)	 = Brzo (slabo izolirano)  = Sporo (dobro izolirano)	0

1.5 Meldingen / Messages / Messages / Meldungen / Mensajes / Poruke

Foutcodes / Error codes / Codes d'erreur / Fehlercodes / Códigos de error / Kodovi grešaka		
		Fout in verbinding met ketel
		Faulty connection to boiler
		Connexion défectueuse à la chaudière
		Fehler in der Verbindung zum kessel
		Fallo de conexión a caldera
	HR	Pogreška u povezivanju sa bojlerom
		Onjuiste meting ruimtetemperatuur
		Incorrect room temperature reading
		Indication incorrecte de la température ambiante
		Fehlerhafte Messung der Raumtemperatur
		Lectura de temperatura ambiente incorrecta
	HR	Neispravno očitavanje sobne temperaturee
		Regelaar defect
		Controller failure
		Défaillance du régulateur
		Regler defekt
		Fallo del controlador
	HR	Greška u kontroli
		Waterdruk te laag
		Water pressure too low
		Pression d'eau trop faible
		Wasserdruck zu gering
		Presión del agua demasiado baja
	HR	Pritisak vode pre nizak

Achtergrondverlichting / Backlight / Rétroéclairage / Hintergrundbeleuchtung / Retroiluminación /Osvjetlkenje		
 		Uw ketel ondersteunt geen OpenTherm Smart Power
		Your boiler does not support OpenTherm Smart Power
		Votre chaudière ne prend pas en charge OpenTherm Smart Power
		Ihr Kessel unterstützt OpenTherm Smart Power nicht
		Su caldera no es compatible con OpenTherm Smart Power
	HR	Vaš bojler ne podržava OpenTherm Smart Power

1.6 Technische gegevens / Technical data / Caractéristiques techniques / Technische Daten / Características técnicas / Tehmnočki podatci

Dimensions	
	80 x 90 x 32.5 (l x w x h) mm
Power supply	
OpenTherm regulator	OpenTherm
Electrical connection	
OpenTherm regulator	OpenTherm communication. Connection for low-voltage wires
Ambient conditions	
Storage conditions	Temperature: -25 °C +60 °C
	Relative humidity 5% - 90% no condensation
Operating conditions	0 °C - 60 °C
Temperature	
Room temperature	Measurement range: -5 °C +65 °C
	Maximum temperature deviation at 20 °C : 0.3 °C
Temperature control area	5 - 35 °C
Adjustment	Modulating temperature control
	The control can be optimised
Room control	Overshoot: Up to 1 °C
	Temperature variation: Less than 0.25 °C
Adjustment strategies	Adjustment of the room temperature
Features of the controller	
Backlight	Colour: blue
Control precision	Temperature: 0.5 °C
Controls	Rotary and push button
Mounting	Directly on the wall using screws. Or built-in junction box as per standards
Quality marks and compliance with standards	<ul style="list-style-type: none"> ▶ EMC: 2004/108/EC, 55014 ▶ Emission: EN61000-6-3 ▶ Immunity: EN61000-6-2 ▶ Drop test: IEC 68-2-32 ▶ RoHS compliant ▶ OpenTherm V3.0 Smartpower
Protection classification	IP20

NL Remeha B.V.
Postbus 32
7300 AA Apeldoorn
Tel: +31 55 5496969
Fax: +31 55 5496496
Internet: <http://nl.remeha.com>
E-mail: remeha@remeha.com

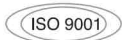

© Autorsko pravo

Sve tehničke i tehnološke informacije koje se nalaze u ovom tehničkom uputstvu, kao i svi crteži i tehnički opisi, ostaju naša svlasništvo i ne smiju se umnožavati bez naše prethodne suglasnosti u pismenoj formi

270111



124675

 **remeha**